

# **RAZR** SGL-11

*500LM*

**Not only a  
desk lamp,  
but also  
a small  
storage box**



SOLAR TABLE LIGHT



Solar & USB



ALS



Safety



Indoor &  
Outdoor



Charging  
temperature



Working  
temperature

# Storage box







## **Anti-glare light**

Built-in 160° TV lens,  
the light is  
more uniform  
and soft

# Dual mode for indoor and outdoor use



Type C charging port,  
easy to store power even  
in rainy days

# Touch button

Four levels of  
brightness switching,  
smooth transition of light  
without a steep drop





**Razr appearance,  
as the name suggests**

<b>Item: SGL-11</b>	
Light Brightness	500 Lumens
<b>Solar panel</b>	
Power	Monocrystalline silicon, 4.86V/1.5W
<b>Li-ion battery</b>	
Capacity	3.7V 7.4WH
Charging / Discharging Temp	0~45°C / -20~60°C
Solar Panel Charging Time	6.7H
USB Charging Time	4.5H
LED	2835, 20pcs
CCT	4000K, Ra>70
Efficiency	160lm/W
Types of Lighting	Anti-glare
<b>Performance</b>	
Lighting Time in Rainy day	>3 days
Lighting Mode	M1: 25% till dawn M2: 50% till dawn M3: 75% till dawn M4: 100% till dawn
Charging Indicator	Red
Switch	Touch Button
Control Mode	1. on and off: long press for 1.5S 2. Short press to switch the lighting mode 3. Change indoor&outdoor mode: Continuously short press 3 times. From outdoor mode switch to indoor mode, lamp flash 3 times. From indoor mode switch to outdoor mode, lamp flash 2 times.
Core Technology	ALS2.3
IP	IP44
Material	ABS
Net Weight	390g



unit: mm

SOLAR TABLE LIGHT

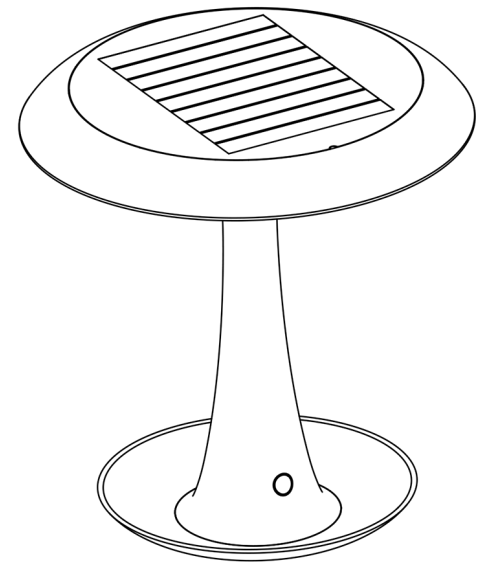
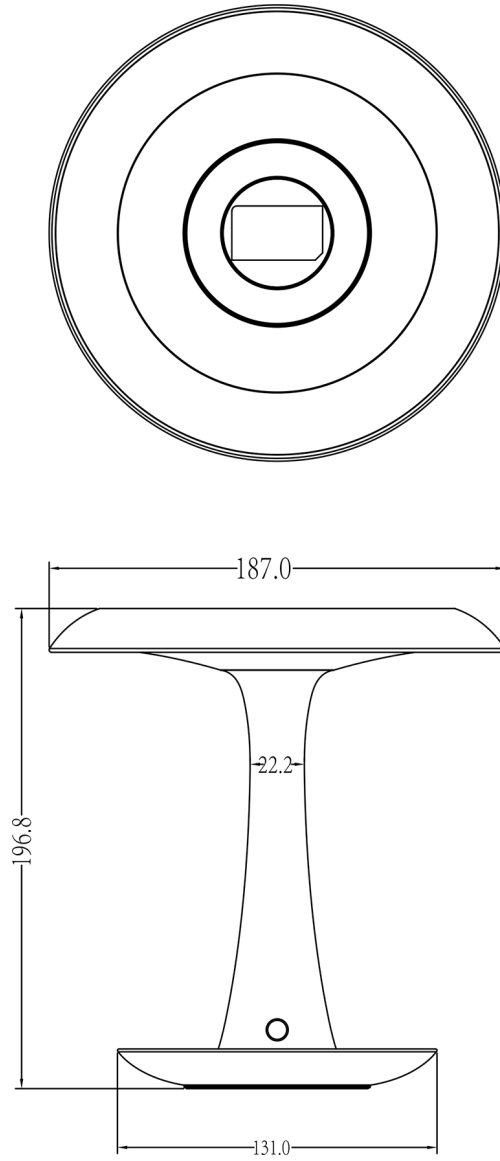



SOLAR TABLE LIGHT



A small storage box



High lumen LEDs 160lm/W

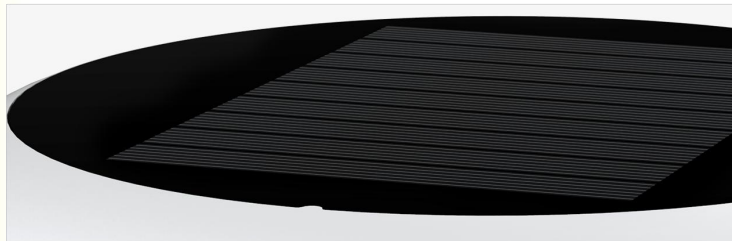

Monocrystalline silicon solar panel



Touch Button



A Great Company should always pay the highest attention to every detail of design, and the craftsmanship spirit should be filled in the whole design process and mass production.



SOLAR TABLE LIGHT

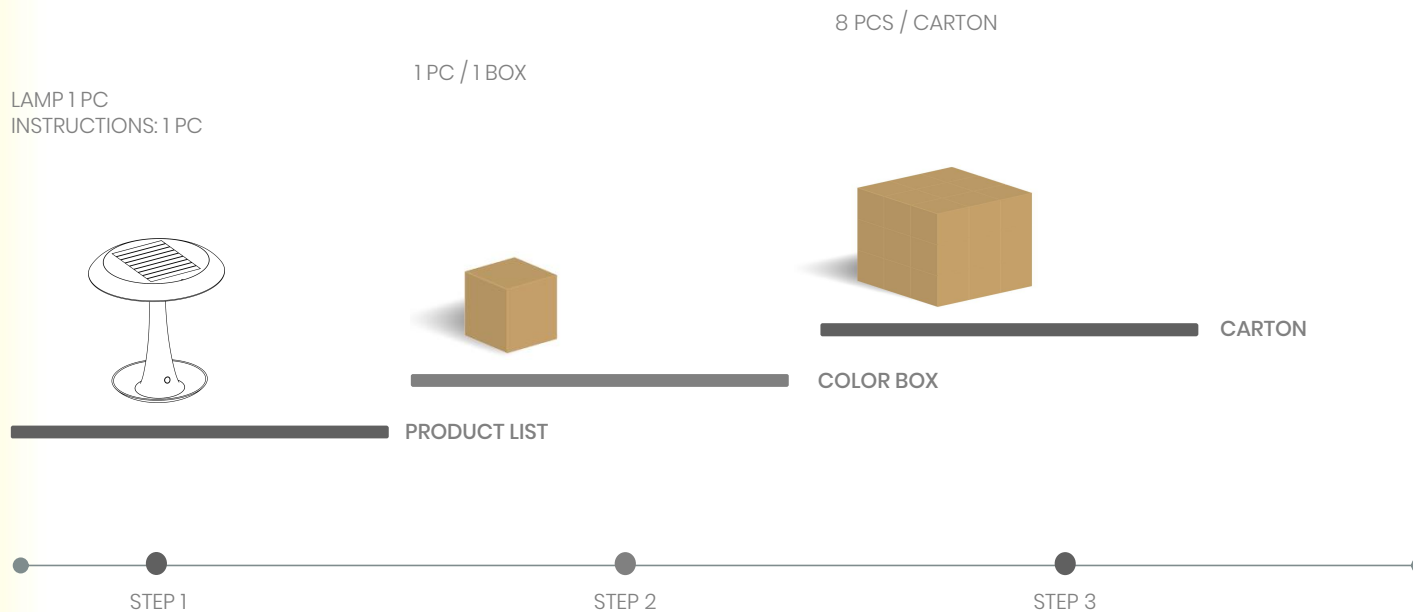

MODEL NO.	PACKING METHOD	PCS/CTN	QTY(PCS)	CTN QTY	CARTON SIZE(MM)	N.W.(KG)	G.W.(KG)
SGL-11	INNER BOX	1	1	1	195*195*215	0.41	0.63
	CARTON	8	8	1	410*410*450	3.28	6.18

Net weight and gross weight are for reference only

SOLAR TABLE LIGHT





S O L A R / T A B L E / L I G H T



INNOVATING  
THE FUTURE OF SOLAR