

INSTRUCTION MANUAL



spatech

CONTROL SYSTEM

Model: SPA-TECH C-III (400)
SPA-TECH C-III (200)

TABLE OF CONTENTS

INSTRUCTION	1
CONTROL SYSTEM FEATURE	1
Compatibility.....	1
Safety	1
Heater control	1
Expansibility	1
SPA-TECH CONTROL PANEL	2
SPA-Tech control panel operation instruction.....	2
Stand-by/Power on.....	3
Temperature setting.....	3
Systemic time setting.....	3
The filtration cycle setting.....	3
Mode setting.....	4
Light Setting	4
Automatically turn off	4
Digital diagnostics function	4
Memory function	4
Extension function.....	4
Default setting	4
DIP SWITCH SETTING	5
SPA-TECH CONTROL SYSTEM CIRCUIT DIAGRAM	6
PROBLEM SHOOTING	7

INSTRUCTION

SPA-Tech control system is specially designed for hot tub spa and swim spa, which is applying with several intelligent control and self-protection technology. According to the numbers of pumps, the system can be divided to two-pumps system, three-pumps system and four-pumps system.

If some parts of the equipment are not available in your product, the related function is not available as well, the related button on the control panel should be ignored accordingly.

The manufacturer reserves the right to modify part of the design or specifications without prior notice and without entering into any obligation.

CONTROL SYSTEM FEATURE

Compatibility

The system can work in single-phase AC 220~240V and three-phase AC 380~415V, while the frequency can be 50Hz or 60Hz.

The system can work well in both circulation-pump system and dual speed-pump system.

The system set up multiple control programs with 12 DIP switches setting.

Safety

The control system has multi-self-protection program: water flow protection, high voltage protection, low voltage protection, low temperature protection, high temperature protection, super high temperature protection, and anti-dry heating protection to guarantee the system run safely.

Control box is made by ABS and its water proof is up to IPX5.

Heater control

The control system come with a built-in heater to heat up the water.

The control system can control heat pump or heat exchanger by setting different DIP of composited program system.

Expansibility

The control system comes with excellent extension, through adding the extended circuit board, assistant control panel to achieve extra function.

SPA-TECH CONTROL PANEL

SPA-Tech control panel operation instruction

NOTES:

1. Above guide is applied to Spa-Tech control panel only.
2. Key 'Jet 1': If it controls a 1-speed pump, it functions 'Turn on/off' for this pump. If it controls a 2-speed pump, it functions 'Turn on at low speed/turn to high speed/turn off'. When the 2-speed pump is turned on, it works at high speed for 6 seconds, then turn to low speed automatically.



KEY	SYMBOL	FUNCTION
Power		Power on / Stand-by
Jet1		Turn on / off pump1
Jet2		Turn on / off pump2
Blower		Turn on / off blower
Light		Turn on/off light, and set light mode
Mode		1. Sleep / Economy / Standard mode 2. Yes / No
Time		Time setting
Up		Adjust Time / Temp (+) / select modes
Down		Adjust Time / Temp (-) / select modes
Time + Up	+	Reverse / non-reverse time and temperature display
Up + Down	+	Panel Locked (PL) / unlock panel
Time + Blower	+	Mode and Setting temperature and Cycle time return to factory Settings
Mode + Jet1	+	The pump work cycle setting

Stand-by/Power on ()

Stand-by: The SPA will automatically entry stand-by mode when the spa is properly connected with power. In the stand-by mode, the current water temperature will appear on the LCD screen, and the thermostatic function and filtration cycle will get started as per the default setting. No back light on the screen.

Note: In the stand-by mode, except “” button and “” button, no buttons are available





Power on: Press the “” button, the screen will be illuminated and all the buttons on the panel will be effective.

Note: When leaving the spa run for one hour without touching any panel’s buttons. The system will automatically go into stand-by mode, and the screen light will be turned off.

Temperature setting ( / )







The SPA comes with thermostatically controlled heater; set the temperature from the control panel, when the actual temperature is lower than the set temperature, the heater will automatically turn on to heat the spa water.



Note: Only the spa equipped with heat pump has the cooling function.

In the power on mode, the screen displays the actual water temperature. When “” or “” button is pressed, the digital number showing the set temperature will flash, press “” or “” again to change the set temperature. After 5 seconds, the digital numbers will stop flashing and begin to display the current spa temperature, temperature setting complete.

To raise the set temperature press the “” button. To lower the set temperature, press the “” button. The temperature set point (set temperature) can be adjusted from 10° C to 40°C.

Systemic time setting ( / )







Press “” button, the current time will be displayed. Program the clock by pressing the “” button and the digital display window will display a digital clock with the HOUR setting flashing. Use the “” or “” buttons to correct HOUR. When the HOUR is correct, press “” button to save changes and go to minutes setting. Use the “” or







“” Buttons to correct MINUTES. When the MINUTES are correct, press the “” button to save changes and complete the time setting.

Notes:

1. The time displayed on the screen is 12-hour clock mode it's with AM and PM to identify, AM means " before midday", and PM means "after midday".
2. If the HOUR and MINUTE of the time don't need to be changed, press "Mode" twice to skip it.
3. Program the time setting as per the above procedures, if leaving the buttons alone for 5 seconds, you will exit the time setting.
The clock will remain ticking when the spa is turned off or powered off suddenly, no need to adjust the time when the spa is turned on again.

The filtration cycle setting ( / )

After setting systemic time, press “”, the “FILTER1, START TIME” appearing on the screen. Select the hour by press “” or “” to set up the start time for 1st filter cycle, press “” enter “FILTER1 END TIME” appearing on the screen. Press “” or “” to set the “ FILTER1 END TIME” for 1st filter cycle. Press “” exit the 1st filter cycle and enter the 2nd filter cycle setting.

Select hour by press “” or “” to set the start time of the 2nd filter cycle setting, press “” enter. Press “” or “” to set the “FILTER2 END TIME” for 2st filter cycle. Press “” to exit programming.

Notes:

1. Only the hours can be set for the filter cycle.
2. If you don't want to change the setting, please press “Mode” to exit. If it is stopped or no operation within 5 seconds during the setting. The system will exit the setting automatically. And the setting is saved.
3. The filtration cycle will run only when the spa is on stand-by mode. In this case, the control panel will show “O3”. When the spa is in power-on mode, the filtration function will stop.
4. Different time setting will be recommended. If the time setting is same, the filtration will be operated for just one time.





Mode setting ()

There're 3 modes, "Standard", "Economy" and "Sleep".

Standard mode: Heater is always on to maintain the set temperature.

Economy mode: The thermostatic function is activated only when filtration cycle. During the filtration period, when the water temperature is lower than the target temperature, the heater will be on.

Sleep mode: Heater will be on only as soon as the water temperature is lower than 11 °C.

How to set the modes: Press "" button to enter the mode setting. Then, press "" or "" button to select different modes. Finally, press the "" button to set the mode.

How to activate economy mode: Economy mode works only under standby status. After setting economy mode, when the SPA power on, it will works in standard mode, the screen will show "standard" signal and at the same time the "economy" signal is flashing. Press the "" button or stay it run for one hour to enter standby status for activating the economy mode.



Light Setting ()

Press the button "" to turn on the light, once again to turn off the light, press the button again to turn the light and change into another mode.

Automatically turn off

If no buttons press for 15minutes (can be adjusted), the on running pump1, pump2 and blowers will automatically turn off. Press the relevant button to start again.

Notes:

1. If the heater is on working and the Jet1 is dual speed pump, then Jet1 will automatically turn to the low speed, and it will not stop running until the heater stop.
2. Press ( + ) to reset the automatic turn off time. There are three options: 15minutes, 30minutes, 60minutes. P15, P30, P60 will display after set.

Digital diagnostics function

The control system will automatically when turn on the protect function after error message appear on the LCD display if there is probably something wrong with the SPA, you can refer to "Trouble shooting" to deal with these problem or provide these information to your dealer.

Plumbing (Hose and pipe) clearing cycle

The system will turn on blower and massage pump high speed for 3~4 minutes to clean the hose and pipe in every filtration cycle.

Memory function

The system will revert to the last setting after each power on.

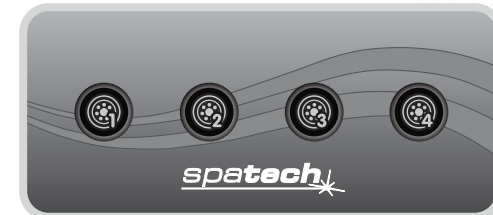

Extension function

The control system can control not only the main control panel for standard equipment, but also can control auxiliary control panel. It can maximum control 4 massage pump through by the auxiliary control panel.

Note: The control system can control up to one auxiliary control panel.

Default setting

Temperature: 38°C.

Model: Standard model.

First filtration cycle (filter 1): (8:00AM-10:00AM or 8:00-10:00).

Second filtration cycle (filter 2): (8:00PM-10:00PM or 20:00-22:00).

The default automatic turned off time of pump is 15 minutes.

DIP SWITCH SETTING

Setting Mode	ON	OFF	Default
1	OFF(DIP 1)/OFF(DIP 2), Heat pump only mode. OFF(DIP 1)/ON(DIP 2),Heater only mode.		According to heater system selected.
2	ON(DIP 1)/OFF(DIP 2), Heater work with Heat pump mode. ON(DIP 1)/ON(DIP 2), Heat exchanger work mode.		
3	Pump 1 is two speed pump, low speed as circulation function	Pump 1 is single speed pump	According to massage pump1 type.
4	Pump 2 is two speed pump	Pump 2 is single speed pump	OFF
5	E8 mode (compressor protection)	E8 mode (dismiss compressor protection)	OFF
6	Fahrenheit Temperature display	Centigrade Temperature display	OFF
7	24 hours timing	12 hours timing	OFF
8	E4 mode (dismiss water flow switch protection)	E4 mode (dismiss water flow switch protection)	ON
9	Dismiss "E5" High/Low voltage protection	"E5" High/Low voltage protection	OFF
10	Standard mode	Hotel project mode	ON
11	OFF (DIP 11)/OFF (DIP 12): Any one water pump running high speed, the heater stop working. OFF (DIP 11)/ON (DIP 12) :Any two pumps running high speed, the heater stop working.		OFF(DIP11)/OFF(DIP12)
12	ON (DIP 11)/OFF (DIP 12): Any three pumps running high speed, the heater stop working. ON (DIP 11)/ON (DIP 12):Any pumps and the heater can run at the same time.		

SPA-TECH CONTROL SYSTEM CIRCUIT DIAGRAM

Circuit diagram for C-III(400) / C-III(200)
 C-III(200) not configured pump3 / pump4

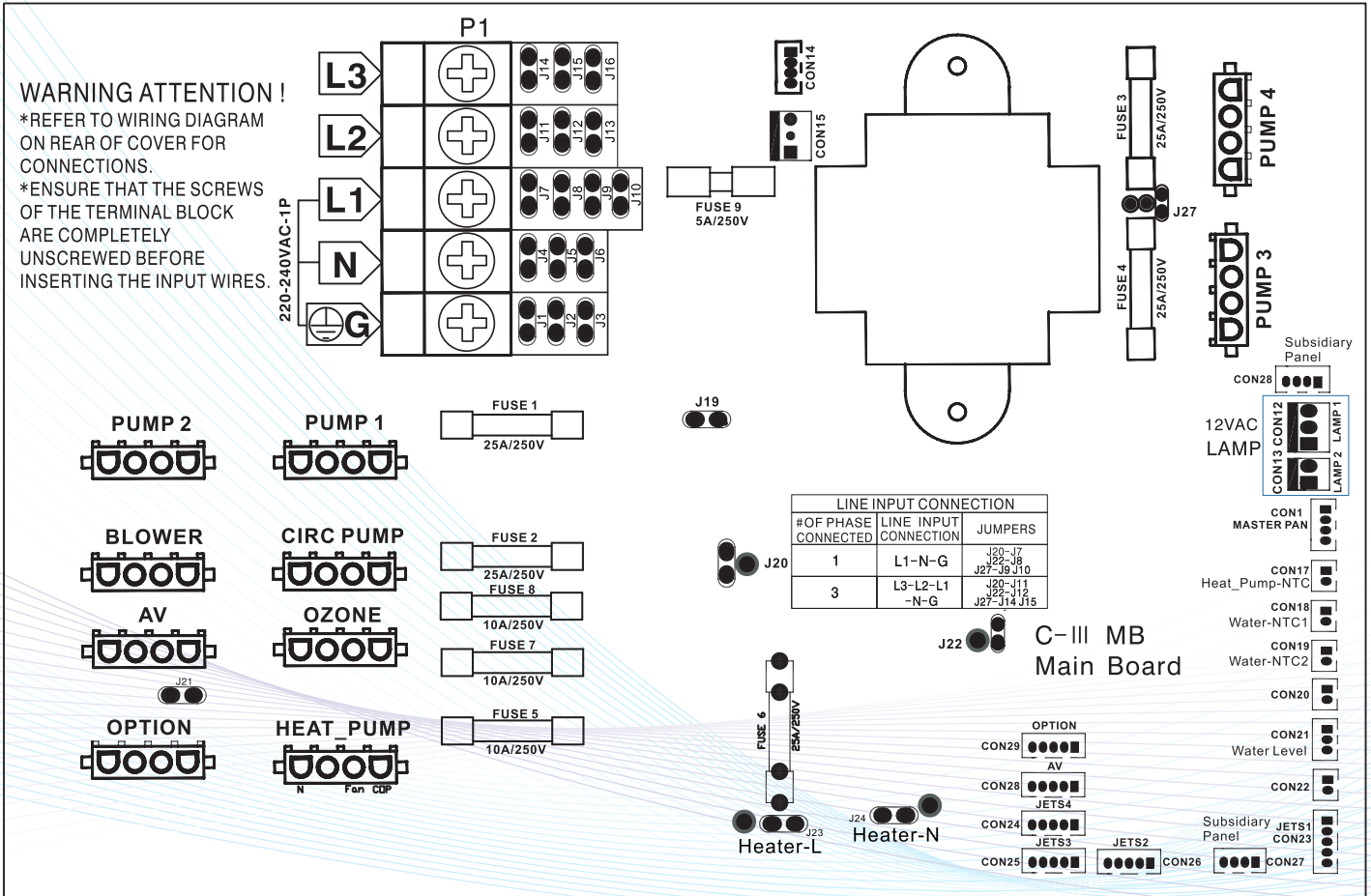

LINE INPUT CONNECTION		
# OF PHASE CONNECTED	LINE INPUT CONNECTION	JUMPERS
1	L1-N-G	J20-J7 J22-J8 J27-J9 J10
3	L3-L2-L1 -N-G	J20-J11 J22-J12 J27-J14 J15

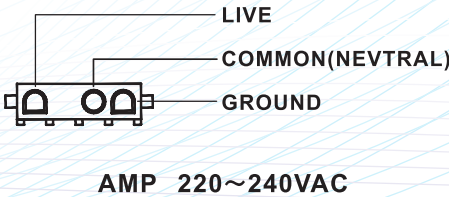

PROBLEM SHOOTING

Protection/fault	Fault display	Reason	Elimination methods
Communication Malfunction	E0	The connection between the control panel and main PCB loosed.	<ol style="list-style-type: none"> 1. Tighten the connection between control panel and main PCB. 2. Contact your dealer, replace the PCB or control panel.
Water temperature sensor 1 protection	E1	<ol style="list-style-type: none"> 1. The connection between the temperature sensor 1 and main PCB loosed. 2. Temperature sensor 1 fault. 	<ol style="list-style-type: none"> 1. Tighten the temperature sensor 1 and control panel following the wiring diagram. 2. Replace the temperature sensor.
Water temperature sensor 2 protection	E2	<ol style="list-style-type: none"> 1. The connection between the temperature sensor 2 and main PCB loosed. 2. Temperature sensor 2 fault. 	<ol style="list-style-type: none"> 1. Tighten the temperature sensor 2 and control panel following the wiring diagram. 2. Replace the temperature sensor.
Heat pump copper tube temperature sensor protection.	E3	<ol style="list-style-type: none"> 1. The connection between the copper tube temperature sensor and main PCB loosed. 2. The copper tube temperature sensor fault. 	<ol style="list-style-type: none"> 1. Tighten the copper tube temperature sensor and control panel following the wiring diagram. 2. Replace the copper tube temperature sensor.
Water flow switch protection	E4	<ol style="list-style-type: none"> 1. The connection between the water flow switch and main PCB loosed. 2. Water flow switch fault. 3. Circulation tube blocked with air. Unscrew the slipknot of the circulation pump to drain out the blocked air in the plumbing. 	<ol style="list-style-type: none"> 1. Tighten the connection between water flow switch and main PCB. 2. Replace the water flow switch. 3. Check and make sure all the side check valves are fully open.
High voltage or low voltage protection.	E5	<ol style="list-style-type: none"> 1. Power supply voltage is higher/ lower than the spa rated voltage. 2. power receptor in PCB fault. 	Cut off the power supply, check and make sure the power supply according to Spa rated power supply requirement.
Inadequate water flow or incorrect water level protection	E9	Inadequate water flow or incorrect water level protection.	<ol style="list-style-type: none"> 1. Check and make sure all the side check valves are fully open. Cut off the power supply, uptight the slip knot of the circulation pump or dual speed pump to drain out the blocked air in the plumbing and power on again. 2. check if the heater sensors broken. 3. If the problem persists, contact your dealer.
Low temperature protection	C	<ol style="list-style-type: none"> 1. Actual water temperature $\leq 6^{\circ}\text{C}$. 2. Temperature sensor fault. 	<ol style="list-style-type: none"> 1. Heater will heat till the spa water temperature has arisen up to 9°C, then the message "C" disappears. 2. If the actual temperature stays below 6°C for long time, please contact your dealer.
High temperature protection	H	<ol style="list-style-type: none"> 1. The detected water temperature $\geq 43^{\circ}\text{C}$. 2. Temperature sensor fault. 	<ol style="list-style-type: none"> 1. Shut off the power and wait till spa water temperature $\leq 41^{\circ}\text{C}$. 2. If the problem persists, contact your dealer.
Over heat protection	HH	<ol style="list-style-type: none"> 1. The detected water temperature $\geq 47^{\circ}\text{C}$. 2. The temperature sensor fault. 	<ol style="list-style-type: none"> 1. Cut off the power supply, wait the water to cool down $\leq 40^{\circ}\text{C}$. 2. If the problem persists, contact your dealer for help.
Control panel locked	PL	The panel is locked.	Press the button "Up" and "Down" simultaneously to unlock the panel.