

Moving
Horizontally



Vertical
Sliding

MARS 2
SOLAR WALL LIGHT

INTRODUCTION

Product specifications

01 FRONT COVER

02 CATALOG

03 MAIN
ADVANTAGES

04 OTHER
ADVANTAGES

05 SPECIFICATIONS

06 EXPLODED
VIEW

07 OPTICAL
FIGURE

08 DIMENTION
FIGURE

09 MORE DETAILS

10 CORE
TECHNOLOGY

11 PACKAGE
DETAIL

12 APPLICATION



2000LUMENS SUPER BRIGHT
EMERGENCY SOLAR WALL LIGHT

Scientific Light Distribution



Product Advantage

Fixture Head 4 Directions Adjustable
(up/down/Right/Left) for Larger Lighting Area



Vertical sliding

**DO AS YOU WISHES,
AMAZING LIKE A MAGIC CUBE.**



Moving Horizontally



Item : SWL-12	Fixture Power : 20W
Solar panel	
Power	Epoxy Mono-Crystalline , 1W
Li-ion battery	
Capacity	3.7V 14.8WH 2AH/PC
Charging/Discharging Temp	0~45°C/-20~60°C
Charging Time	20H
LED (OSRAM)	2835 39pcs ;
Color Temp	4000K , Ra 80+
Efficiency	190lm/W
UV LED	-
Performance	
Lighting Time in Rainyday	>10days
Control Mode	Button Switch , ON/OFF Long Press 1.5s
Lighting Mode	M1 : 50+PIR (2000 lm) / M2 : 0+PIR (2000 lm) /M3:50lm Till dawn -
Mode Indication	M1 : Flash for one time , M2 : Flash for two times ; M3 : Flash for three times
Capacity Indication	-
PIR	120° , >5m
Core technology	ALS 2.3 / TCS 1.0
Solar Panel Autoclean	-
IP/IK Class	IP65 / IK10
Install Height	3m

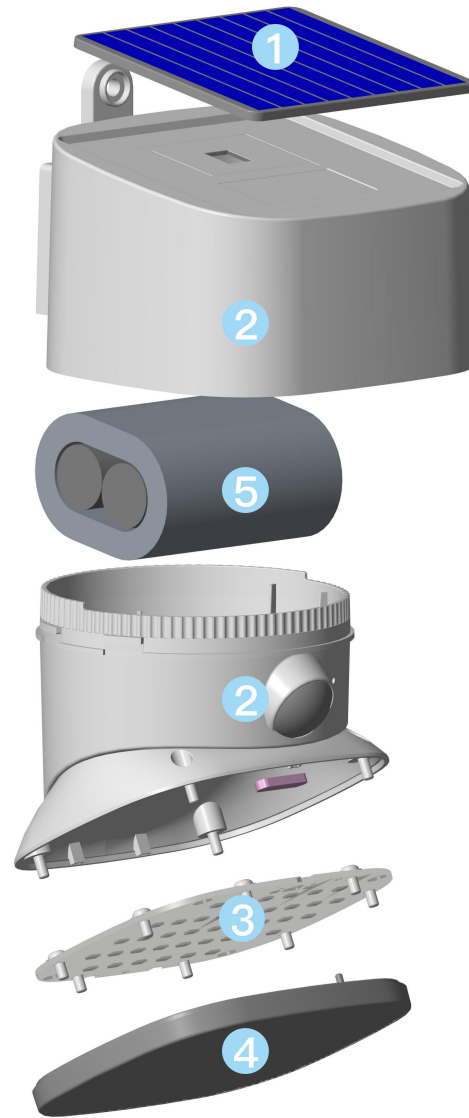

Solar panel



product shell



Led plate



optical lens



battery pack

Road Simulated Diagram

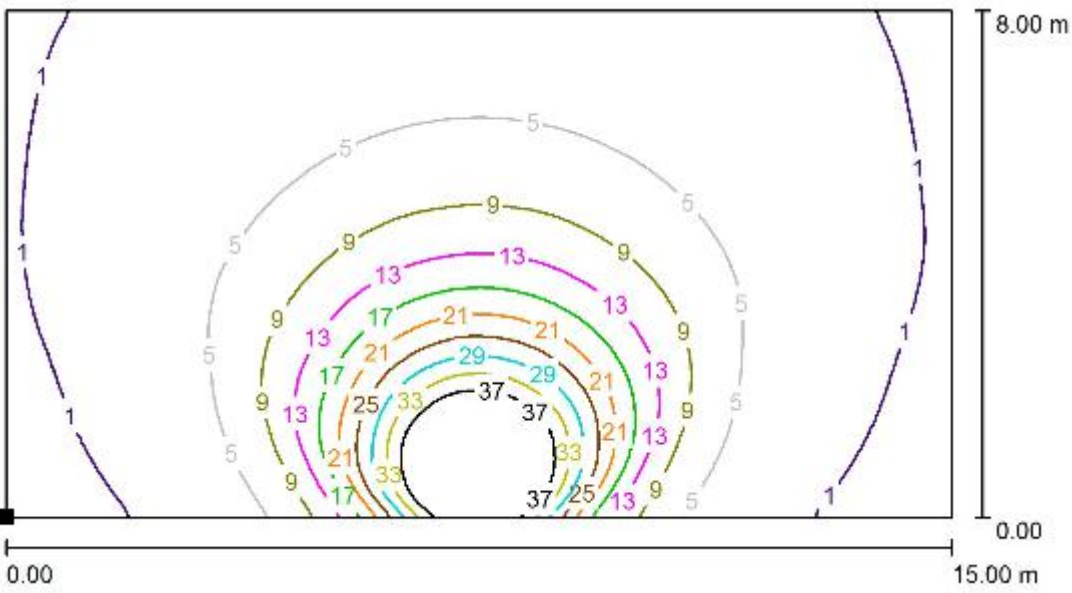

Illumination Curve

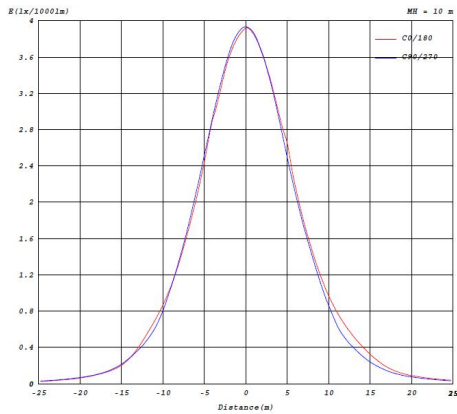

Luminance Distribution

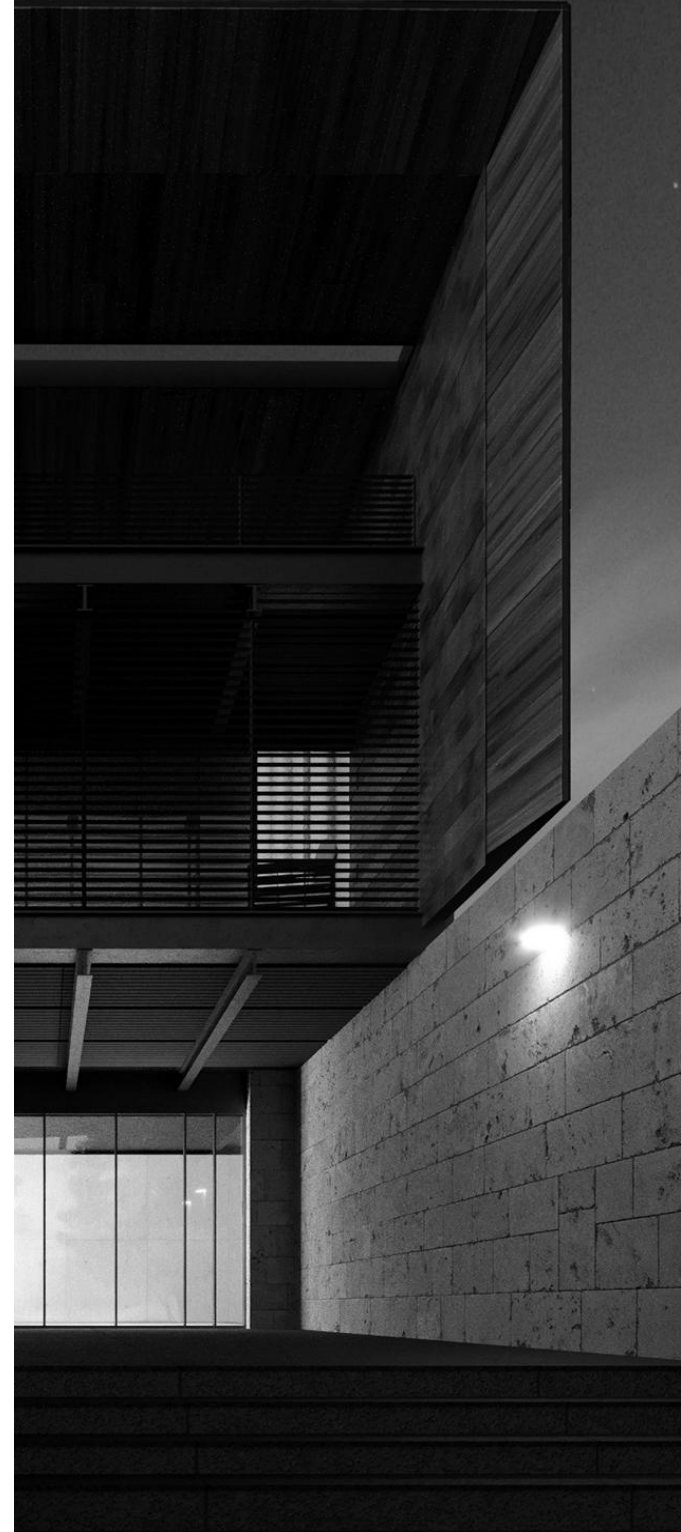
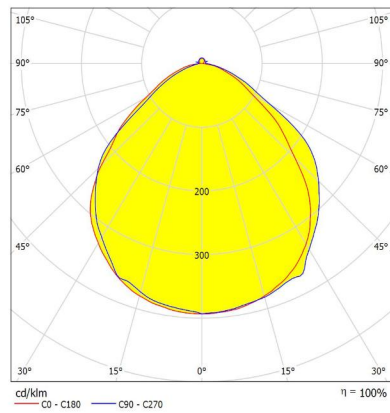

SOLAR LIGHT I DIMENTION FIGURE

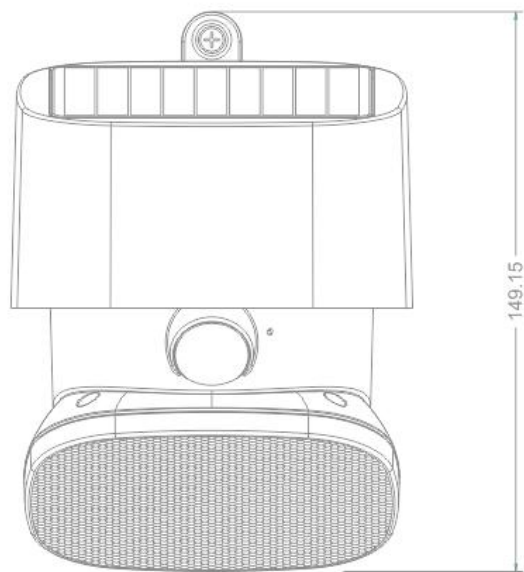
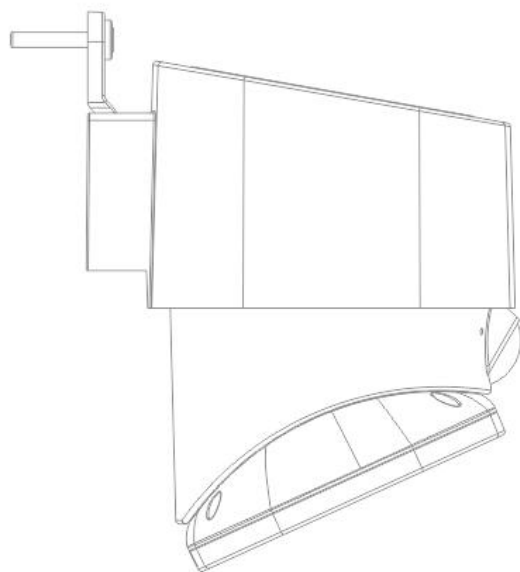
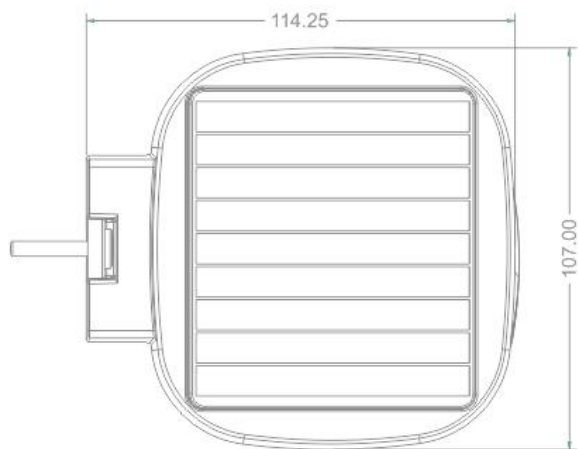

Advantage in every detail

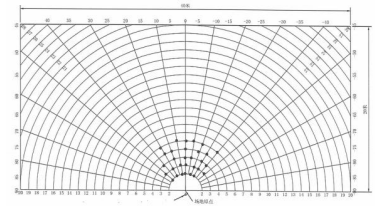

Monocrystalline
Solar Charging Efficiency : >21%

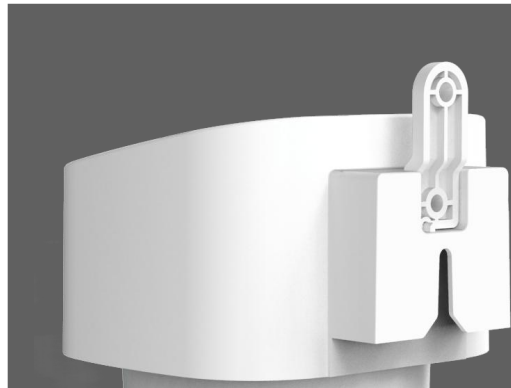

Easy to install



High sensitivity PIR sensor
Switches



Vertical sliding

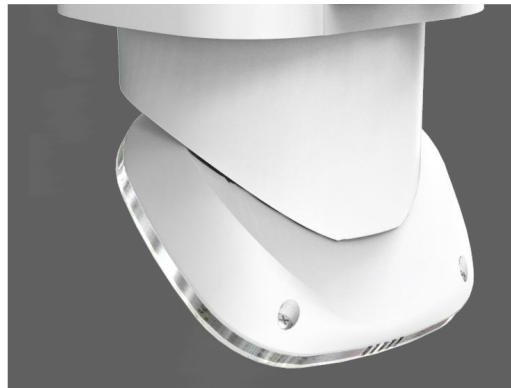

Back details

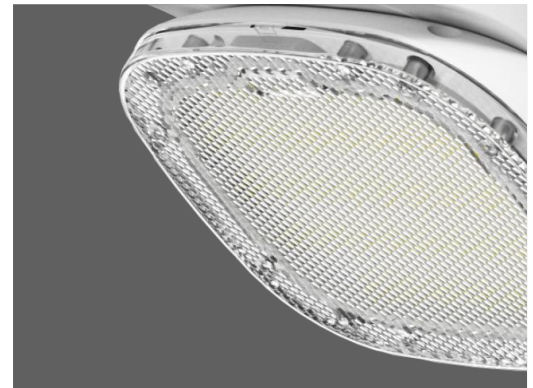

High lumen LEDs
190lm/W



A Great Company should always pay the highest attention to the every detail design , and the craftsmanship spirit should be filled in the whole design process and mass production.

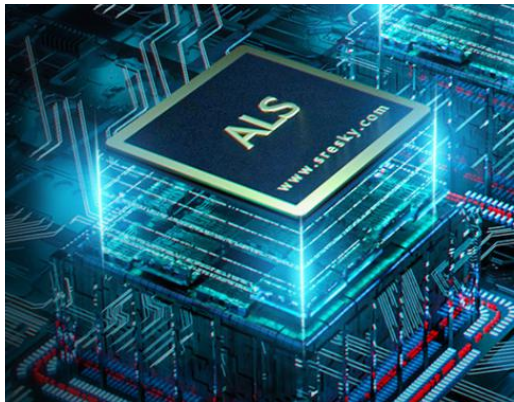

ADVANTAGE OF ALS

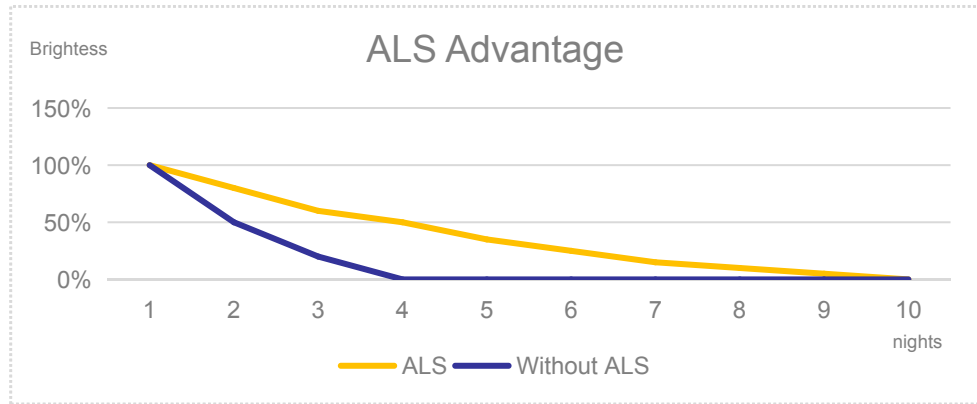

ADVANTAGE OF TCS

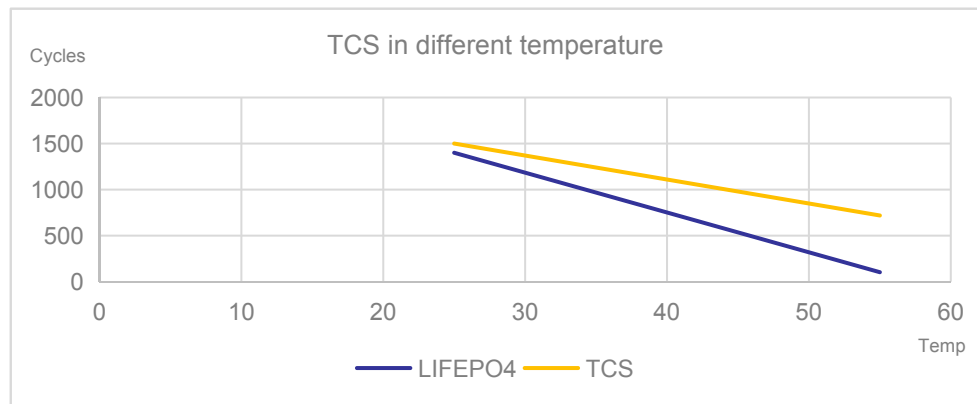

PRODUCT LIST

SCREW : 3PCS
 EXPANSION SCREWS : 2PCS
 ACCESSORIES : 1PC
 PIN: 1PC

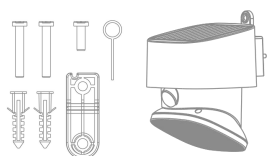

INNER COLOR BOX
 SIZE: 113*125*140mm
 1PCS/1 BOX



2 LAYERS
 1 LAYER = 12 BOXES

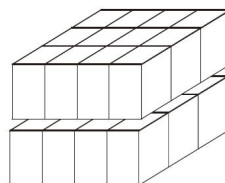

MASTER CARTON
 SIZE: 467*387*298mm
 24PCS/CTN

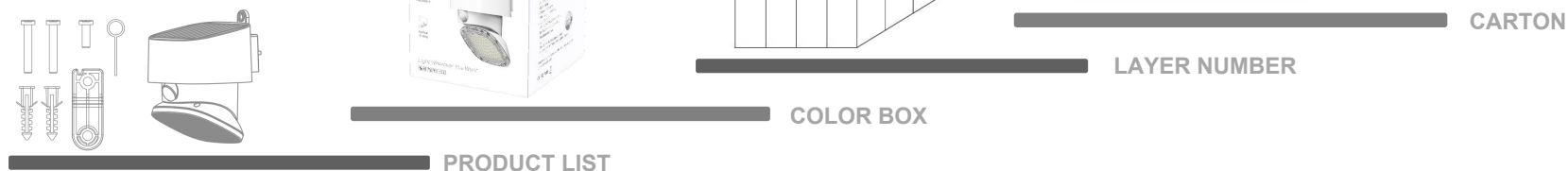
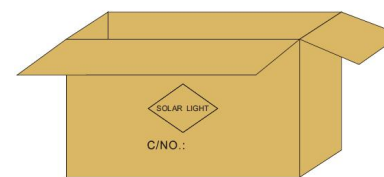

MODEL NO.	PACKING METHOD	PCS/CTN	QTY(PCS)	CTN QTY	CARTON SIZE(MM)	N.W.(KG)	G.W.(KG)
SWL-12	COLOR BOX	1	1	1	113*125*140	0.5	0.55
	CARTON	24	24	1	467*387*298	12	12.5

Net weight and gross weight are for reference only

S / O / L / A / R / L / I / G / H / T

THANKS
VERY
MUCH

